

REVISIONS			
LTR	DESCRIPTION	DATE	APPROVED
A	QUICK TWIST SERIES	01/01/2004	JAG

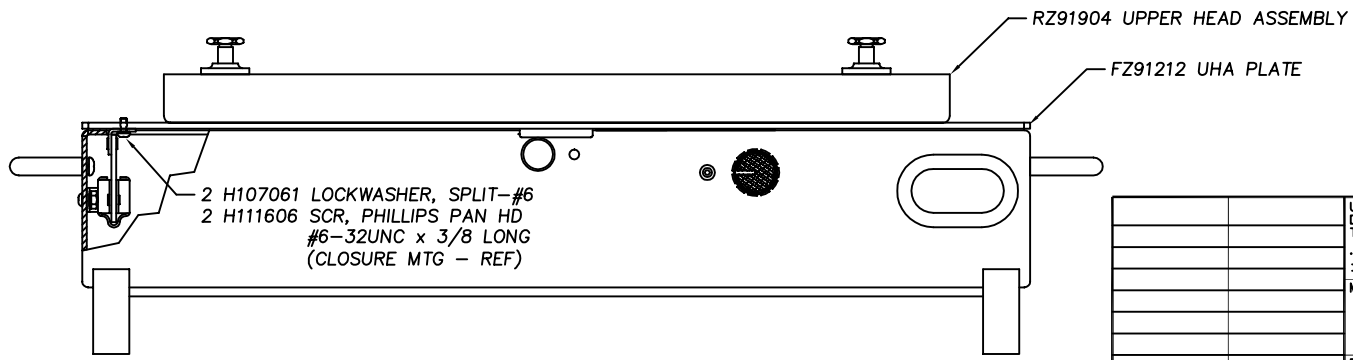
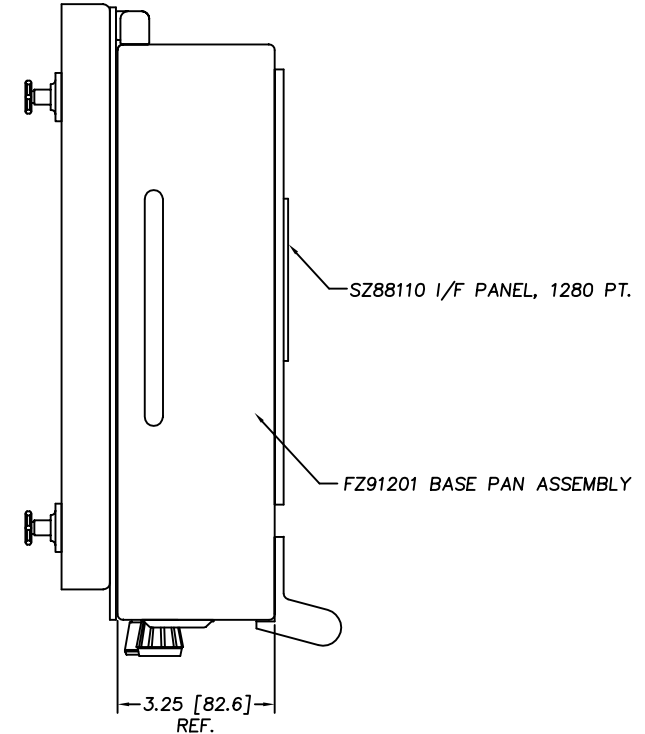
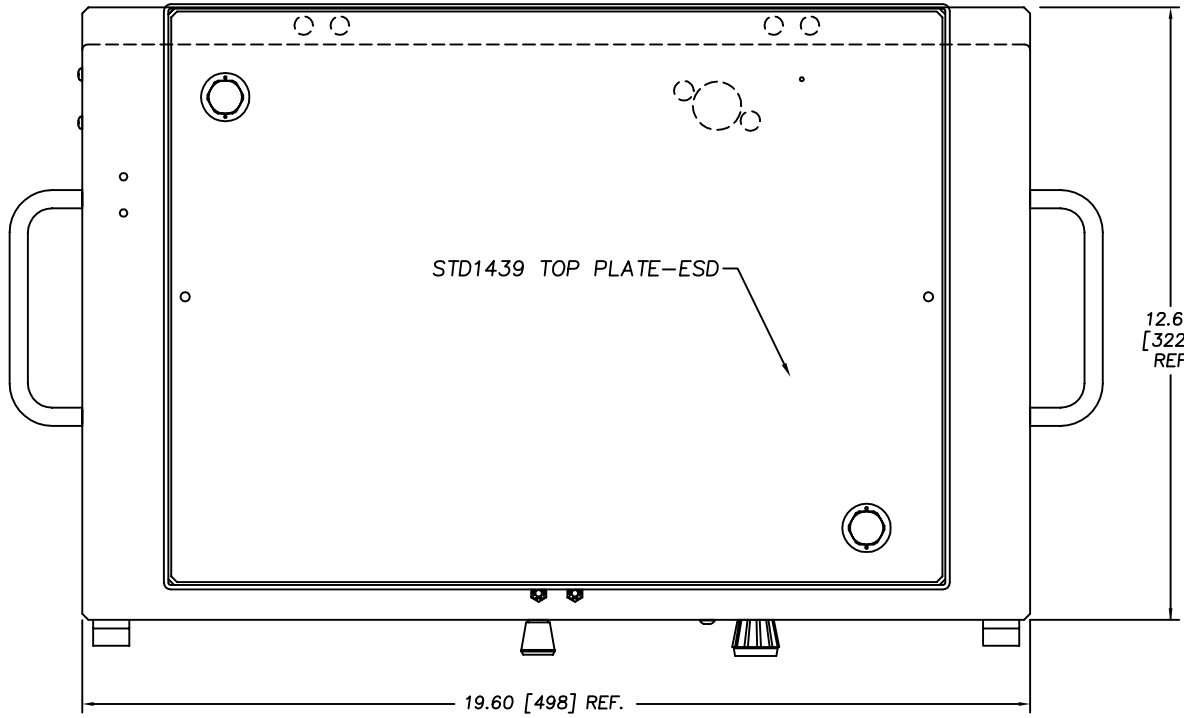

THIS DRAWING IS FOR ASSEMBLY REFERENCE ONLY.

UNLESS OTHERWISE SPECIFIED  
DIMENSIONS ARE IN INCHES [MM]  
TOLERANCES ARE:  
.XX .XXX ANGLES  
±.015 ±.005 ±1/2°  
MATERIAL  
SEE BILL OF  
MATERIALS

**H+W TEST PRODUCTS**  
SEEKONK, MASSACHUSETTS

FIXTURE ASSY (10x14 UUT)  
TERADYNE SPECTRUM 8851

FINISH	NONE	SIZE	FSCM NO.	DRAWING NO.	REV.
NEXT ASSY	USED ON	D		RZ91004	A
APPLICATION	DO NOT SCALE DRAWING	SCALE	FULL	DRAWN	JAG 04/25/2002
		SHEET	1	OF	1

FILE NO.  
RZ91004A