

REVISIONS			
LTR	DESCRIPTION	DATE	APPROVED
A	QUICK TWIST SERIES	01/01/04	JAG

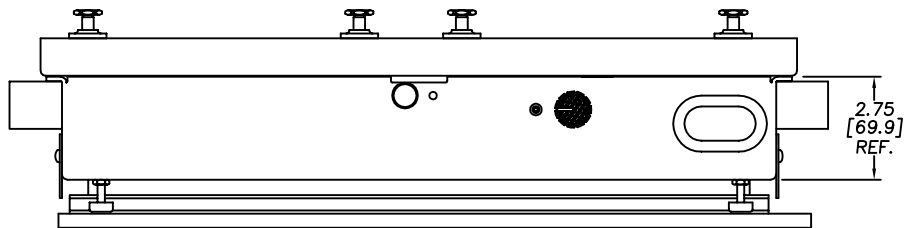

- 8 H005006 SPRING, COMP.
.30 DIA. x .50 LONG
- 8 H115808 SCR, SHOULDER
.188 DIA. x 1/2 LONG
#8-32UNC x 1/4 LONG

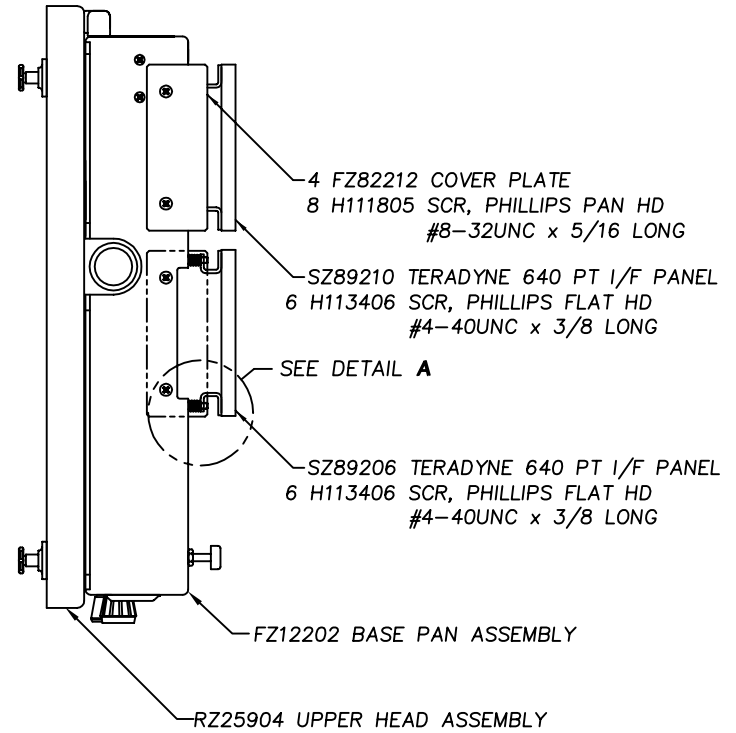
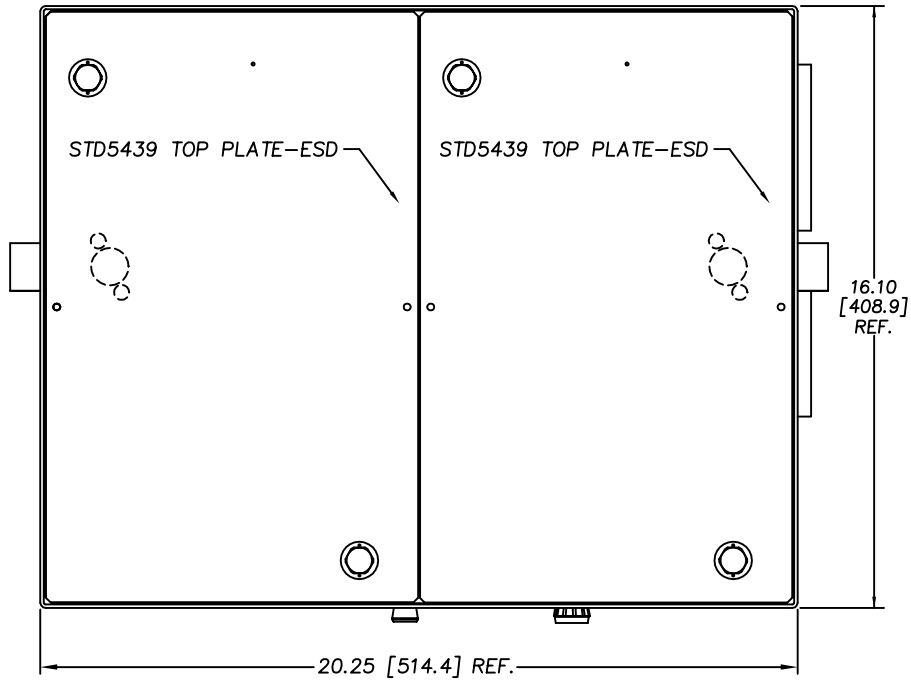
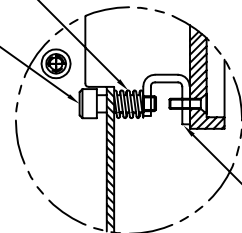

DETAIL A

4 FZ12215 I/F PANEL STIFFENER

		UNLESS OTHERWISE SPECIFIED DIMENSIONS ARE IN INCHES (MM) TOLERANCES ARE: .XX .XXX ANGLES ±.015 ±.005 ±1/2°	H+W TEST PRODUCTS SEEKONK, MASSACHUSETTS	
		MATERIAL SEE BILL OF MATERIALS	FIXTURE ASSEMBLY TERADYNE 1820 (14x8 UUT)	
		FINISH NONE	SIZE E	REV. A
NEXT ASSY	USED ON	SCALE FULL	DRAWN JAG	7/18/96
APPLICATION		DO NOT SCALE DRAWING	SHEET 1 OF 1	

FILE NO.
RZ25004A