

REVISIONS			
LTR	DESCRIPTION	DATE	APPROVED
A	QUICK TWIST SERIES	01/01/04	JAG

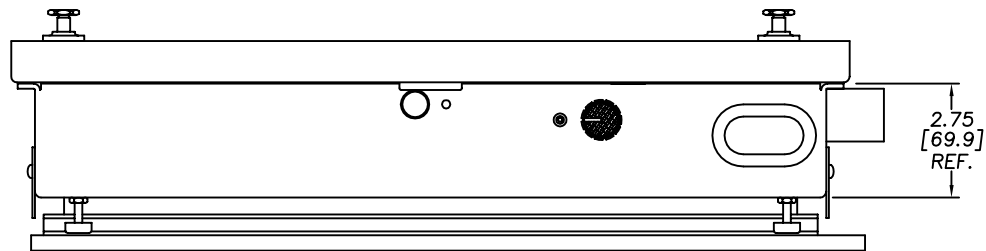
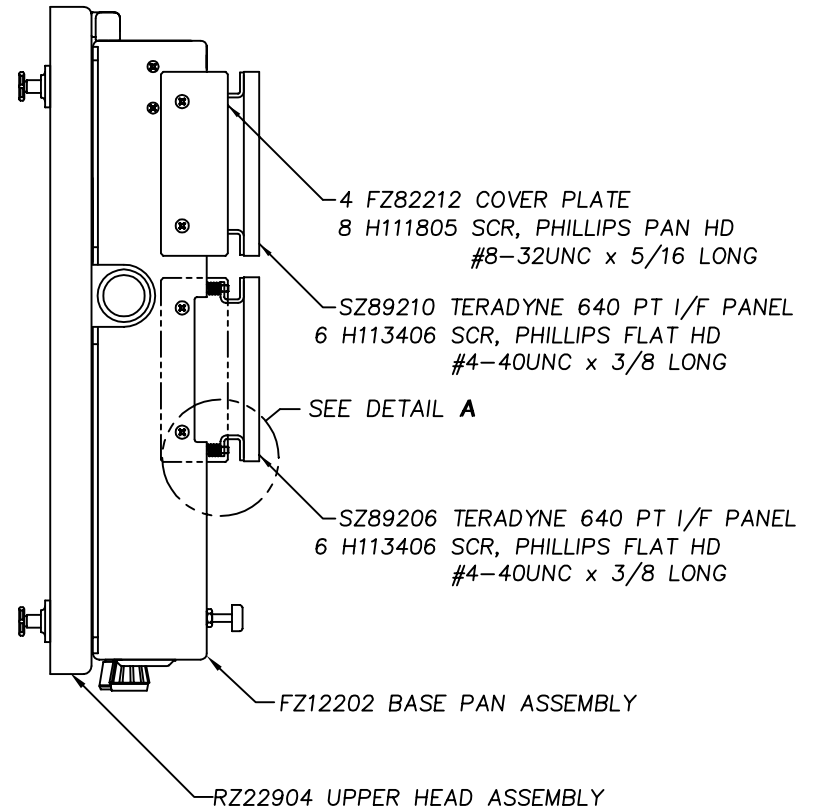
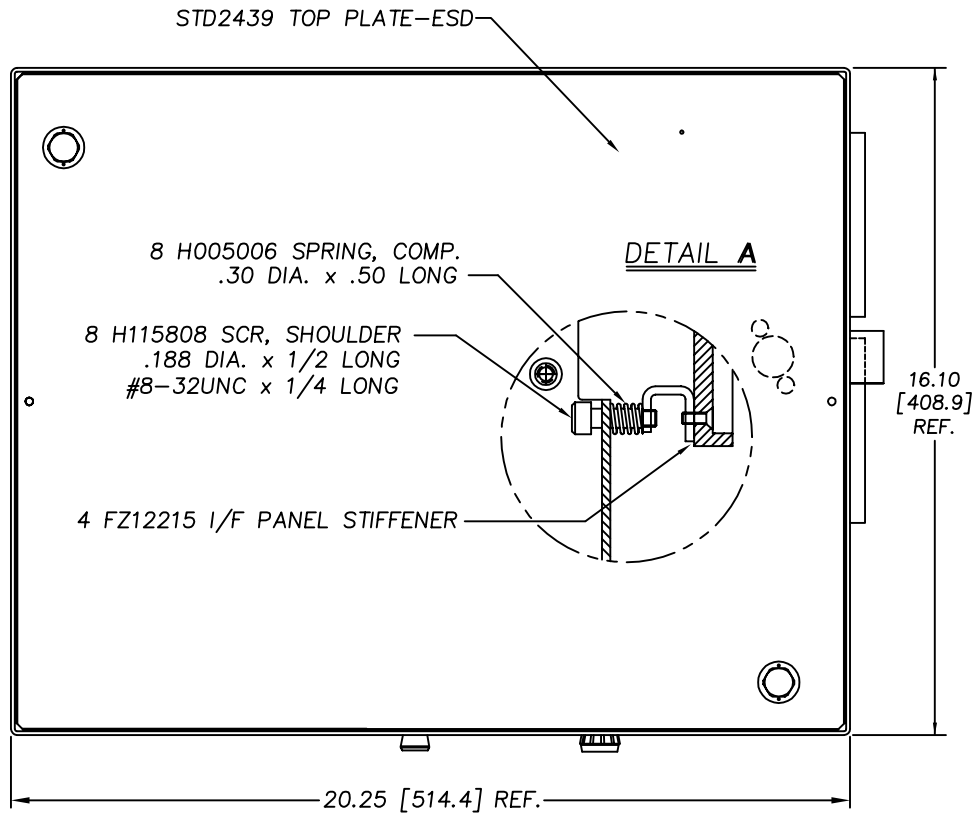

FILE NO.
RZ22004A

		UNLESS OTHERWISE SPECIFIED DIMENSIONS ARE IN INCHES (MM) TOLERANCES ARE: .XX .XXX ANGLES ±.015 ±.005 ±1/2°	H+W TEST PRODUCTS SEEKONK, MASSACHUSETTS		
		MATERIAL SEE BILL OF MATERIALS	FIXTURE ASSEMBLY TERADYNE 18XX (14x18 UUT)		
		FINISH NONE	SIZE E	FSCM NO.	DRAWING NO. RZ22004 A
NEXT ASSY		USED ON	REV.		
APPLICATION		DO NOT SCALE DRAWING	SCALE FULL	DRAWN JAG	7/18/96 SHEET 1 OF 1