

REVISIONS			
LTR	DESCRIPTION	DATE	APPROVED
A	QUICK TWIST SERIES	01/01/04	JAG

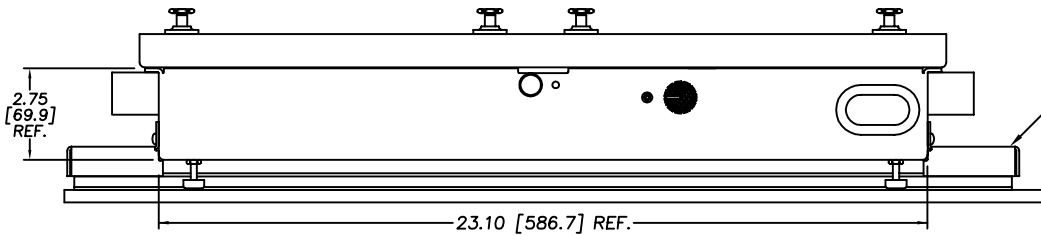

- 8 H005006 SPRING, COMP.
.30 DIA. x .50 LONG
- 8 H115808 SCR, SHOULDER
.188 DIA. x 1/2 LONG
#8-32UNC x 1/4 LONG

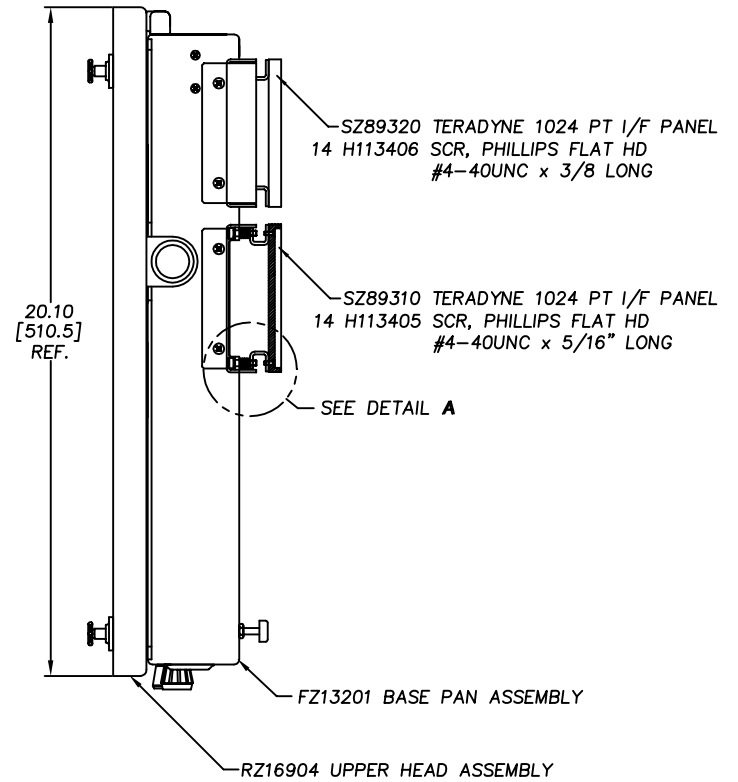
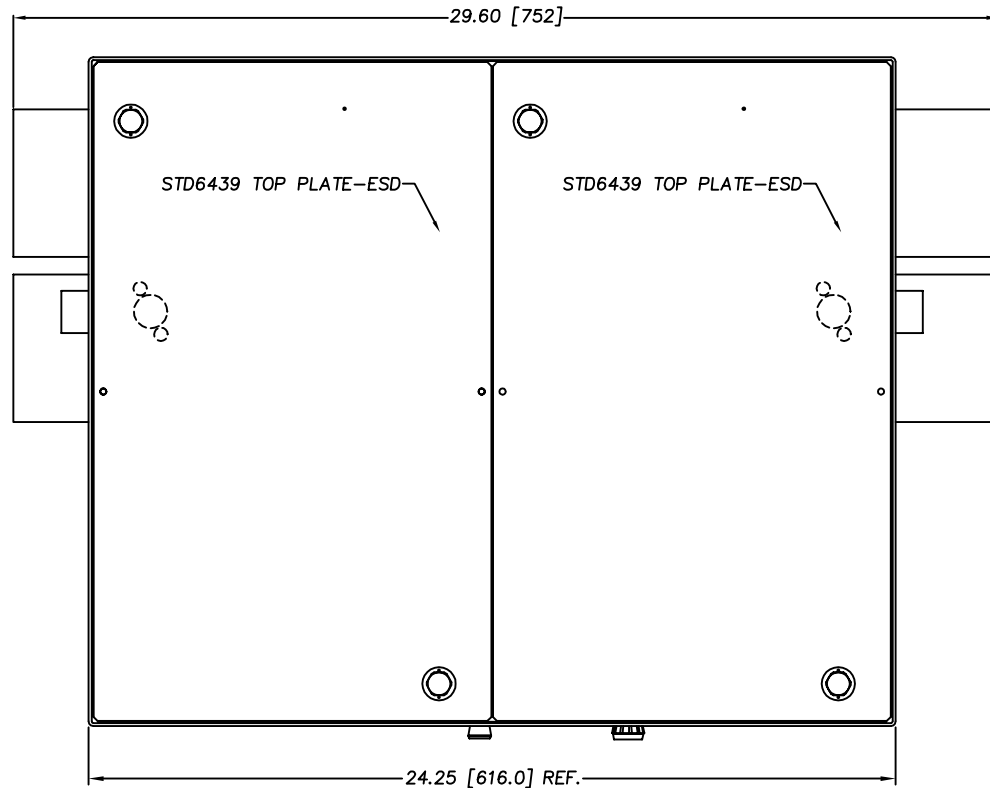
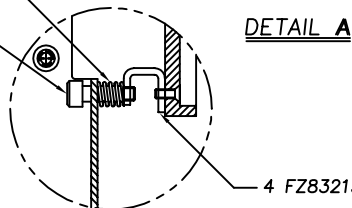

		UNLESS OTHERWISE SPECIFIED DIMENSIONS ARE IN INCHES (MM) TOLERANCES ARE: .XX .XXX ANGLES ±.015 ±.005 ±1/2"	H+W TEST PRODUCTS SEEKONK, MASSACHUSETTS		
		MATERIAL SEE BILL OF MATERIALS	FIXTURE ASSEMBLY TERADYNE 1820 (18x10 UUT)		
		FINISH NONE	SIZE E	FSCM NO.	DRAWING NO. RZ16004 A
NEXT ASSY APPLICATION		USED ON	SCALE FULL		REV. A
		DO NOT SCALE DRAWING	DRAWN JAG		7/18/96
			SHEET 1 OF 1		

FILE NO.
RZ16004A