

REVISIONS			
LTR	DESCRIPTION	DATE	APPROVED
A	QUICK TWIST SERIES	01/01/04	JAG

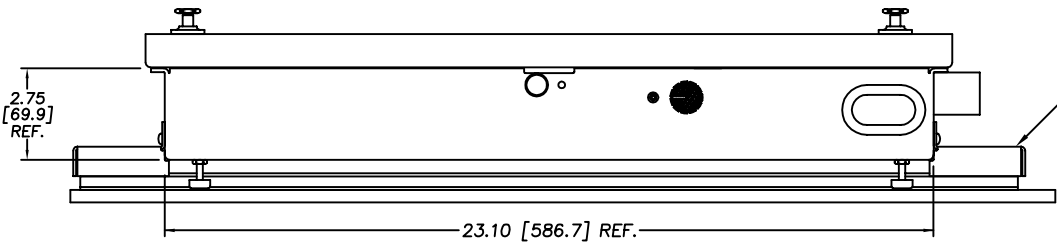

- 8 H005006 SPRING, COMP.
.30 DIA. x .50 LONG
- 8 H115808 SCR, SHOULDER
.188 DIA. x 1/2 LONG
#8-32UNC x 1/4 LONG

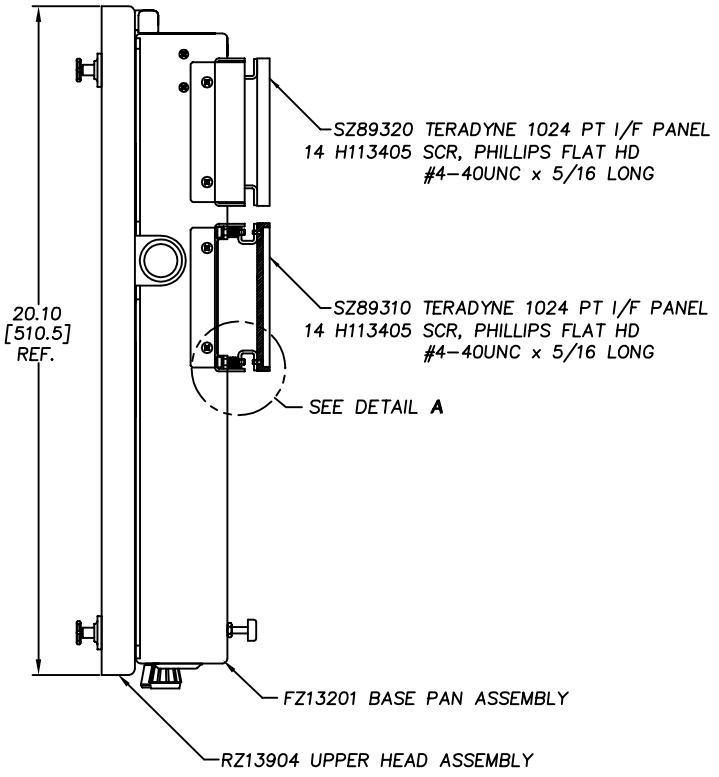
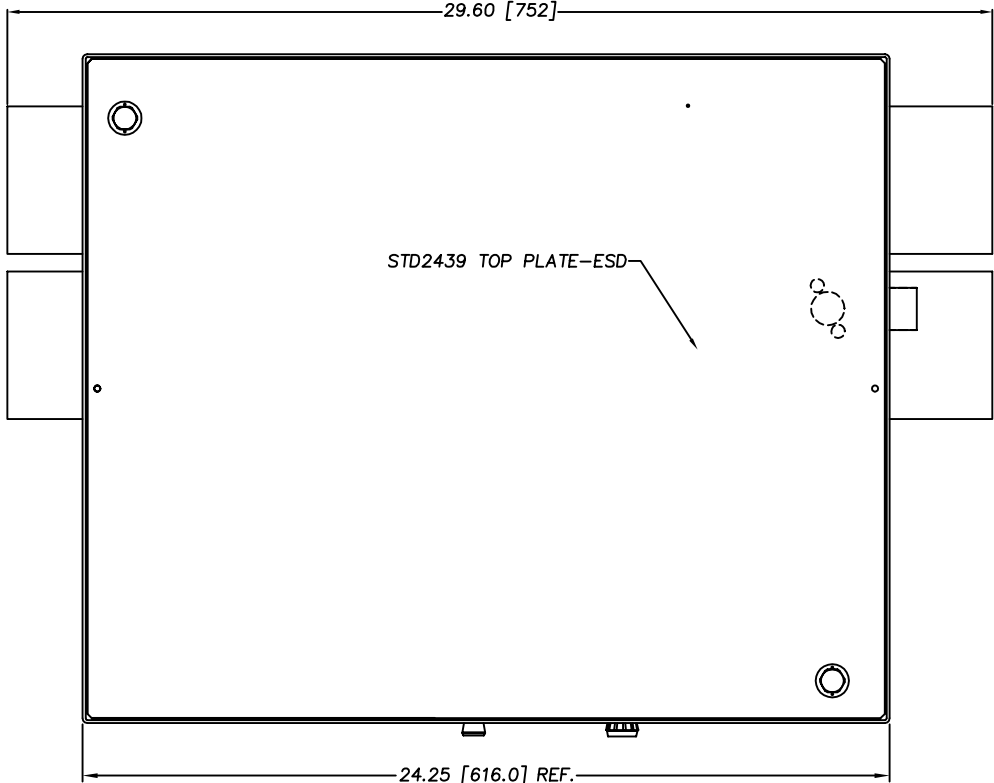
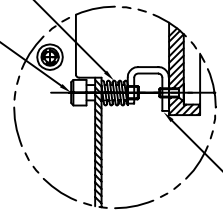

DETAIL A

4 FZ83215 I/F PANEL STIFFENER

		UNLESS OTHERWISE SPECIFIED DIMENSIONS ARE IN INCHES (MM) TOLERANCES ARE: .XX .XXX ANGLES ±.015 ±.005 ±1/2°	H+W TEST PRODUCTS SEEKONK, MASSACHUSETTS	
		MATERIAL SEE BILL OF MATERIALS	FIXTURE ASSEMBLY TERADYNE 1820 (18x22 UUT)	
		FINISH NONE	SIZE E	FSCM NO. DRAWING NO. RZ13004 A
NEXT ASSY	USED ON	APPLICATION	DO NOT SCALE DRAWING	SCALE FULL DRAWN JAG 7/18/96 SHEET 1 OF 1

FILE NO.
RZ13004A