

REVISIONS			
LTR	DESCRIPTION	DATE	APPROVED
A	RELEASE TO PRODUCTION	3/05/99	JAG

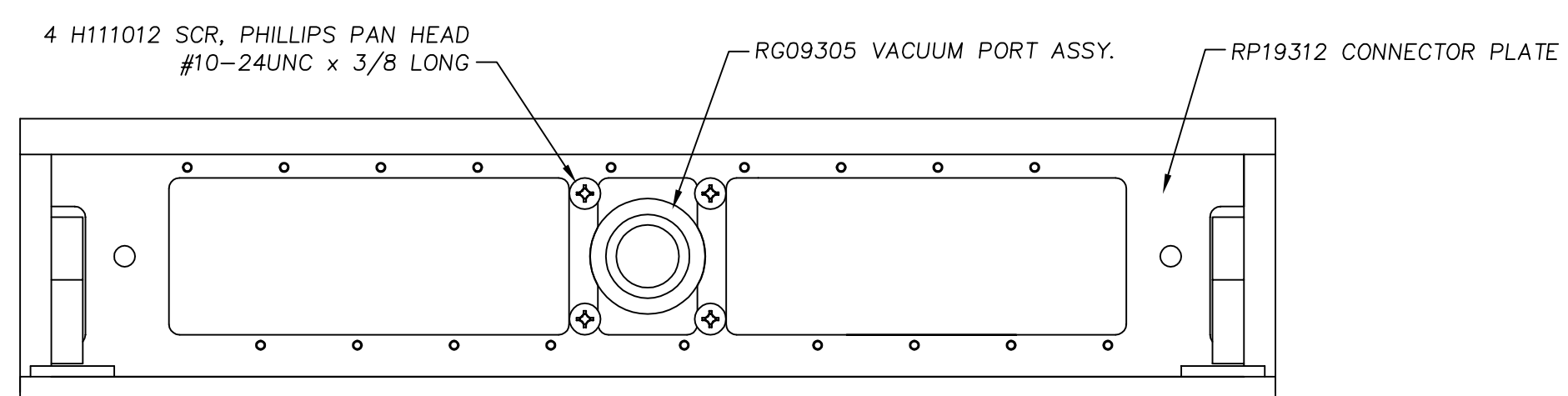
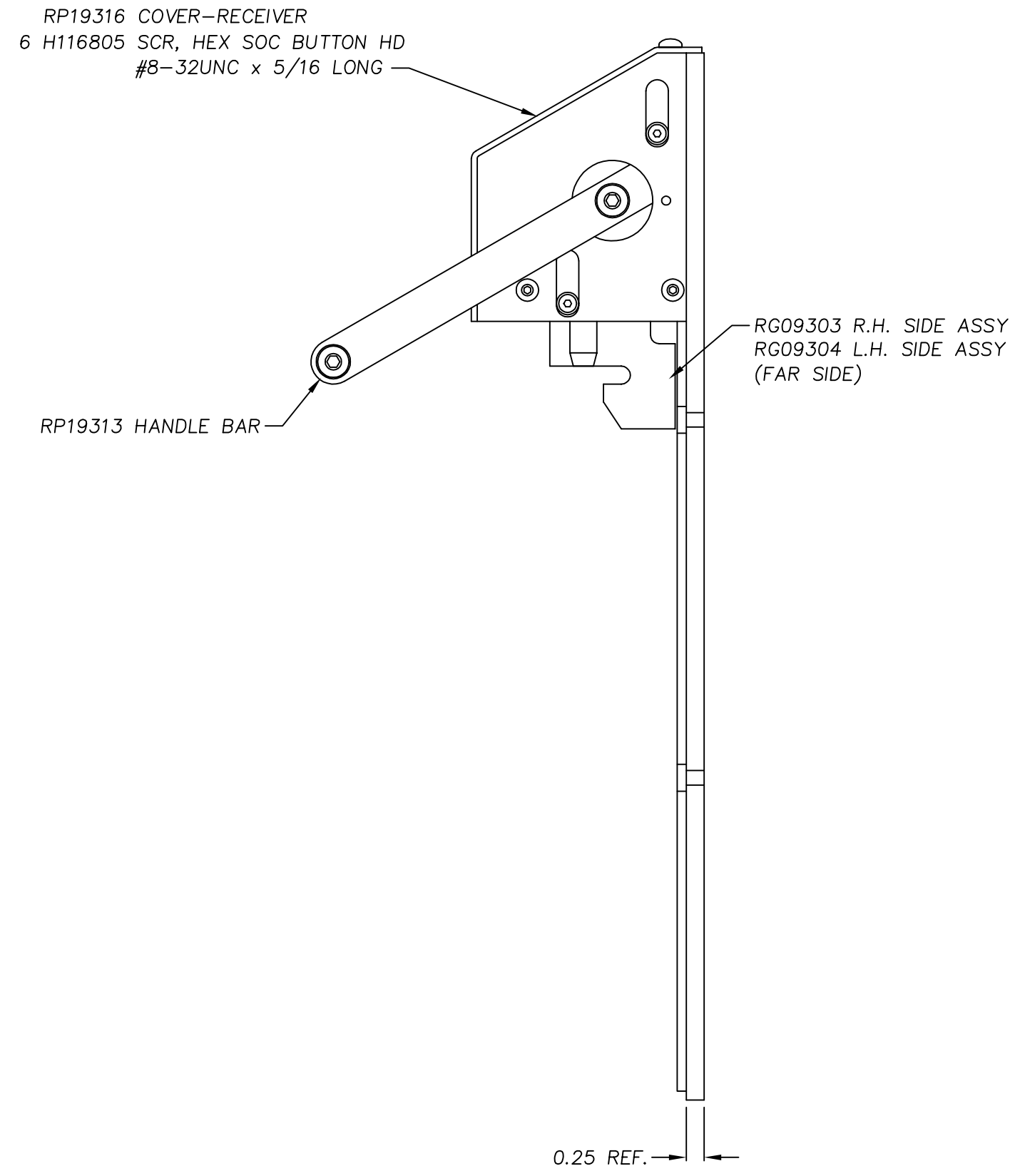
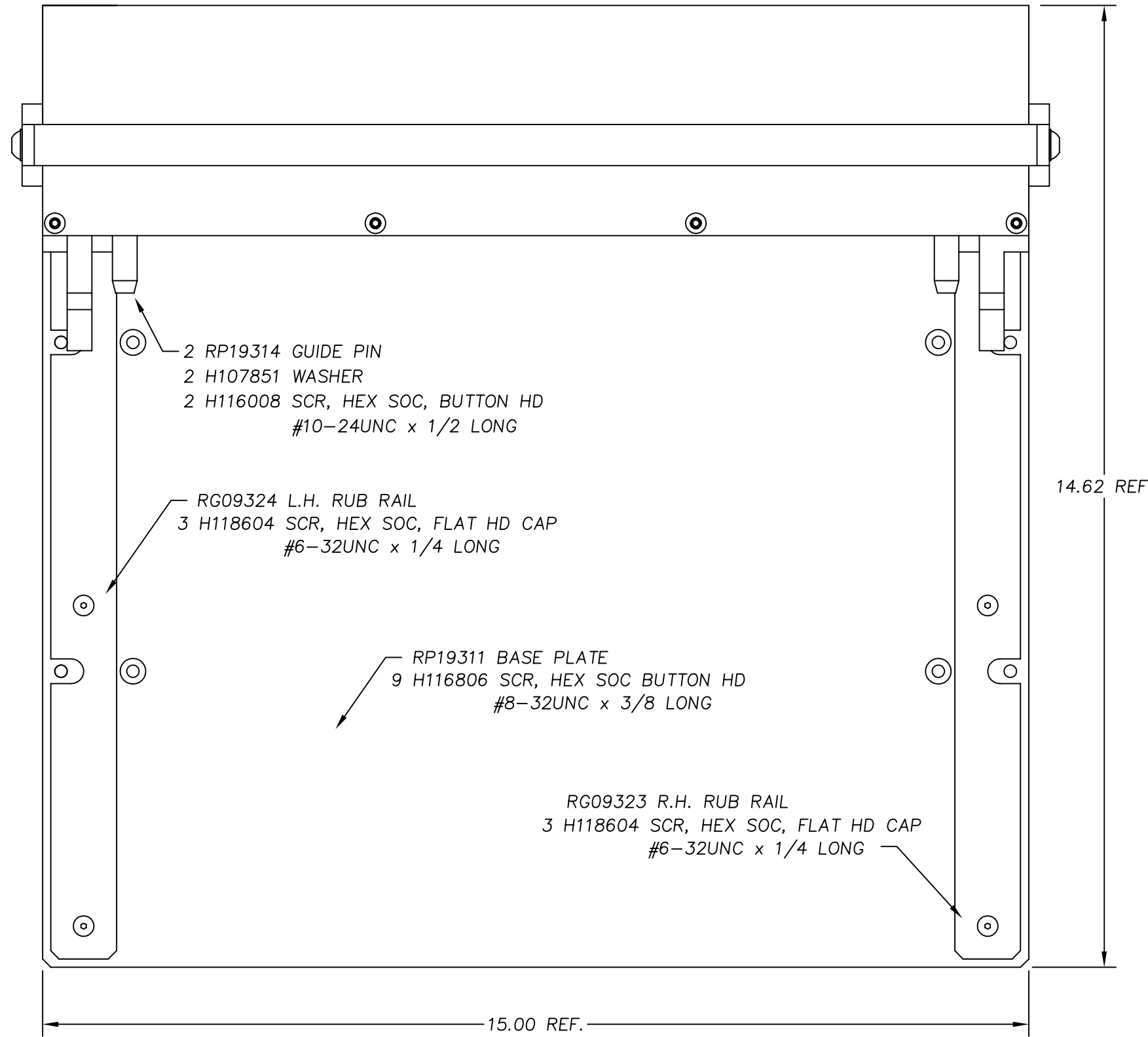

		UNLESS OTHERWISE SPECIFIED DIMENSIONS ARE IN INCHES (MM) TOLERANCES ARE: .XX .XXX ANGLES ±.010 ±.005 ±1/2°	H+W TEST PRODUCTS SEEKONK, MASSACHUSETTS	
		MATERIAL SEE BILL OF MATERIALS	RECEIVER ASSEMBLY PYLON 1280 PT.	
		FINISH NONE	SIZE D	FSCM NO.
			DRAWING NO. RP19001	
			REV. A	
NEXT ASSY	USED ON	APPLICATION	SCALE FULL	DRAWN JAG
		DO NOT SCALE DRAWING	03/05/99	SHEET 1 OF 1

FILE NO.
RP19001A