

REVISIONS			
LTR	DESCRIPTION	DATE	APPROVED
A	QUICK TWIST SERIES	11/10/95	JAG

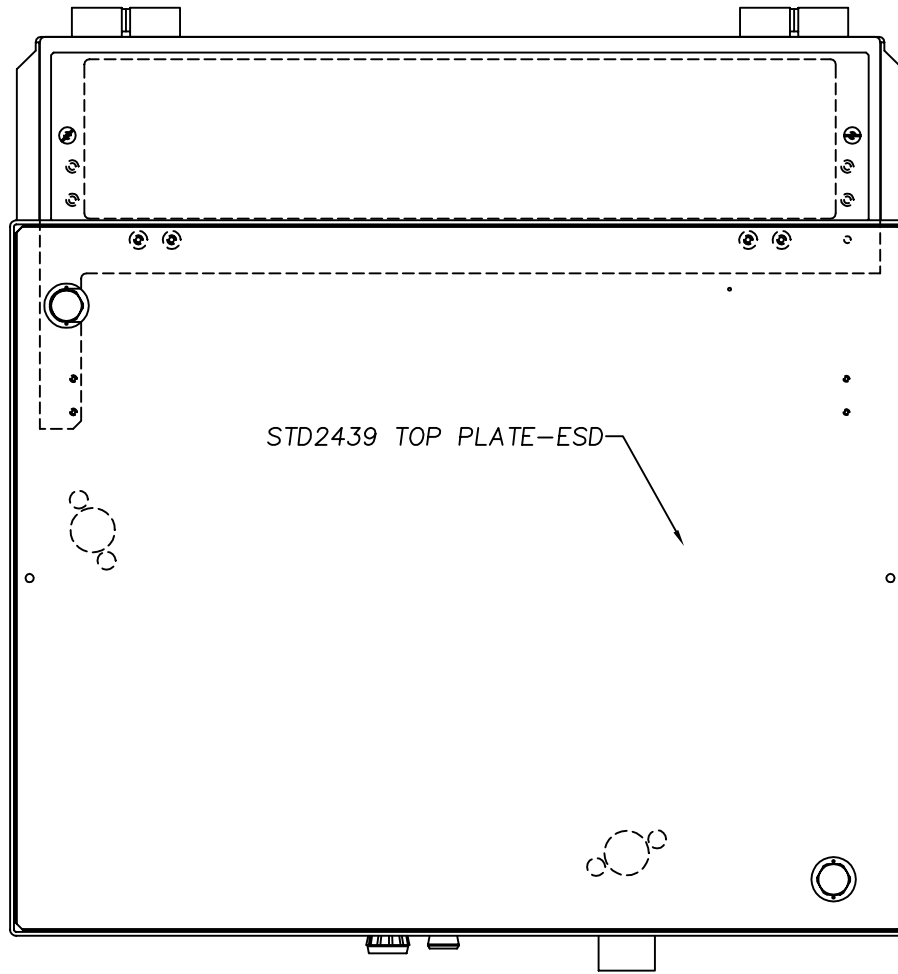

STD2439 TOP PLATE-ESD

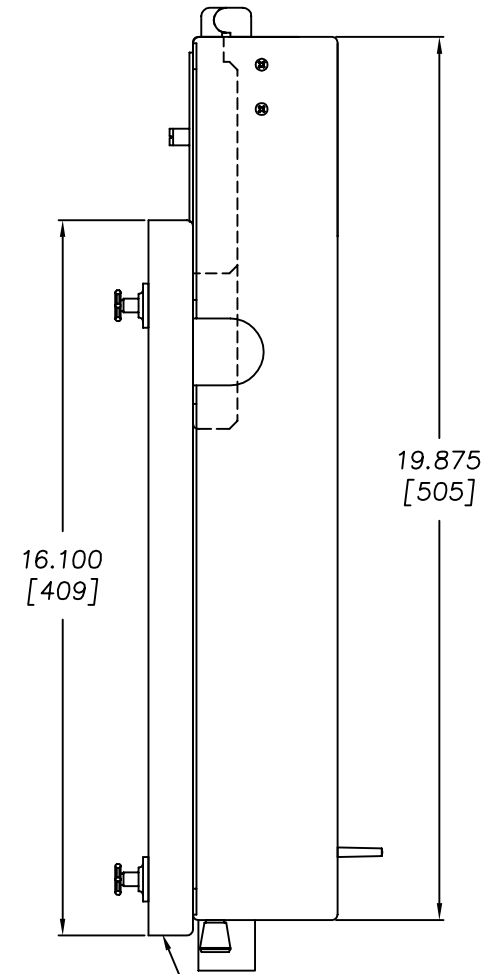

16.100
[409]

19.875
[505]

RF02904 UPPER HEAD ASSY

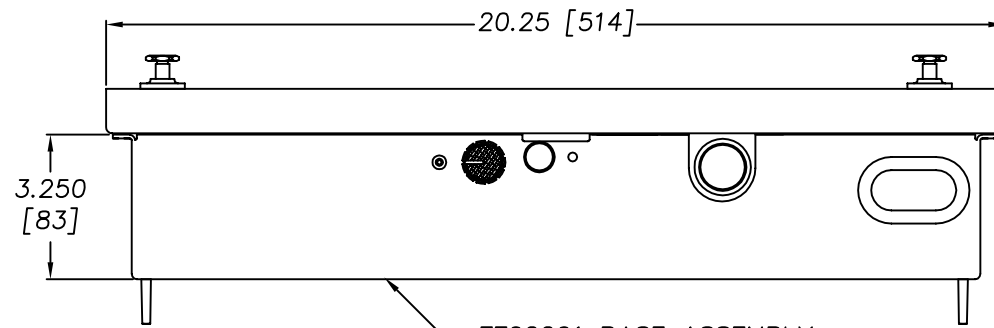

20.25 [514]

3.250
[83]

FF02201 BASE ASSEMBLY

		UNLESS OTHERWISE SPECIFIED DIMENSIONS ARE IN INCHES (MM) TOLERANCES ARE:		H+W TEST PRODUCTS SEEKONK, MASSACHUSETTS	
		.XX	.XXX	ANGLES	
		±.010	±.005	±1/2°	
		MATERIAL		FIXTURE ASSEMBLY	
		SEE BILL OF MATERIALS		FACTRON 303/333 (14x18 UUT)	
		FINISH		SIZE	FSCM NO.
		NONE		E	
NEXT ASSY		NEWSEISSM		DRAWING NO.	
RF02004A				RF02004 A	
APPLICATION		DO NOT SCALE DRAWING		SCALE	FULL DRAWN JAG 11/10/95 SHEET 1 OF 1

FILE NO.
RF02004A