

REVISIONS			
REV.	DESCRIPTION	DATE	APPROVED
A	RELEASE TO PRODUCTION	1/17/92	FMKIRR

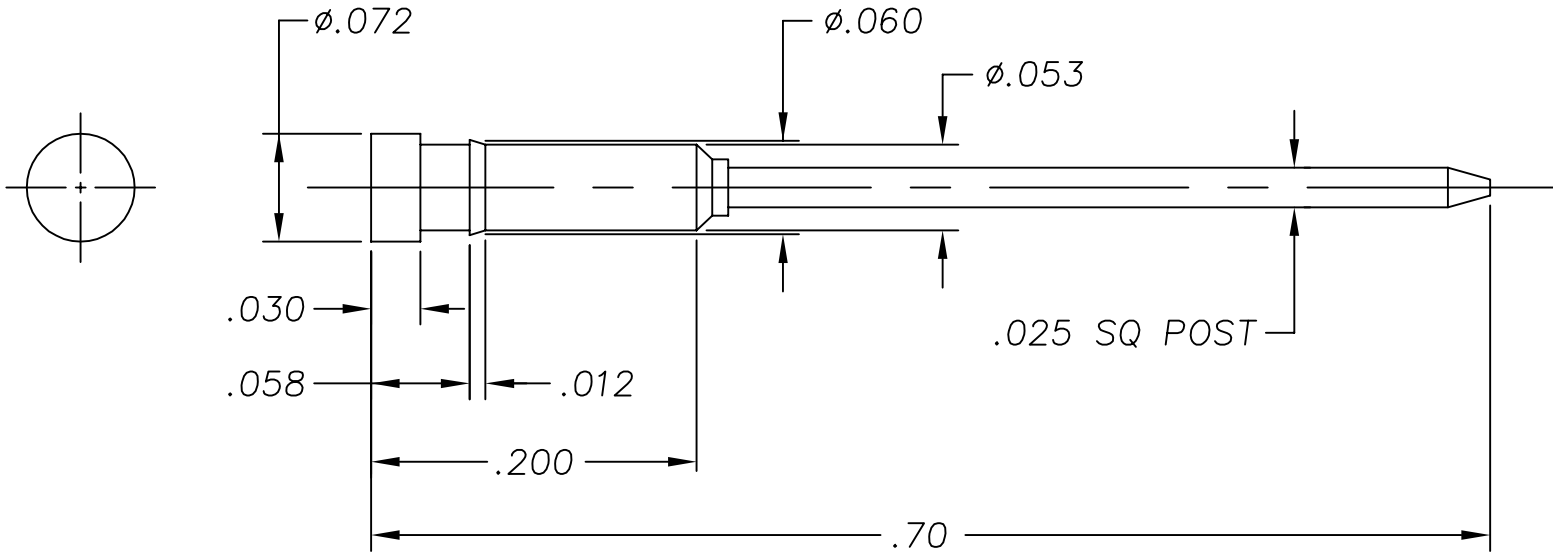

- NOTES:
1. TUMBLE ELECTRO-PLATE GOLD $.000010$ MINIMUM OVER BRIGHT NICKEL PLATE $.000050/.000100$ THK.

UNLESS OTHERWISE SPECIFIED DIMENSIONS ARE IN INCHES (MM) TOLERANCES ARE: .XX .XXX ANGLES $\pm .010$ $\pm .003$ $\pm 1^\circ$		CONTRACT NO.		 SEEKONK, MASSACHUSETTS					
		APPROVALS						DATE	
MATERIAL BRASS		DRAWN FMK		4/16/91		CONTACT PIN, INTERFACE			
FINISH SEE NOTE 1		CHECKED							
NEXT ASSY	USED ON	ISSUED				SIZE A	FSCM NO.	DWG. NO. H190005	REV. A
APPLICATION		DO NOT SCALE DRAWING				SCALE FULL		SHEET 1 OF 1	